

WET AREA PANELLING

Designer Walls. Fast

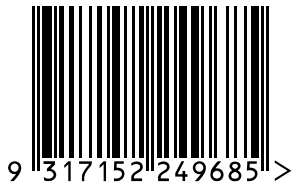

Wall **ART**

Linear Series

WLSBROA5BUN / V9 / OCT 2019



FOREST**ONE** PTY LTD ABN 35 004 051 003
FREE CALL: 1300 088 0667
www.forest1.com

Available at
BUNNINGS
warehouse

Wall **ART**

Linear Series

LINEAR SERIES WET AREA PANELLING



Designer White (Tile)

Add a touch of class to your home or workplace with the Linear Series, WallART's line of wet area panelling. With a striking range of colours and patterns to choose from, you're sure to create a space that's not only functional, but stylish, too.

WATER RESISTANT The Linear Series is perfect for any indoor space that collects moisture, including the bathroom, kitchen, laundry and shower recess.

DURABLE Made from high-pressure laminate it can withstand impact far greater than ceramic tiles, and will not discolour or fade. Being non-porous allows it to perform even in humid conditions like shower recesses.

HYGIENIC The Linear Series will not attract mould because it is grout-free. This also makes cleaning a breeze — simply wipe with a damp cloth and non-abrasive cleanser.

STYLISH The Linear Series offers you a range of attractive styles, from classic monochromes to contemporary patterns. Its streamlined finish makes it a versatile alternative to conventional tiles.

SIMPLE TO INSTALL Our easy-to-follow installation guide enables you to give your space a professional look at just a fraction of the cost, without the need for backing materials.

The Linear Series. Streamlined style.



Snow White

SHEET COLOURS



Designer White (Tile)



Snow White ▲◆●

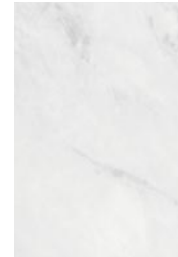

Carrara Ice ▲◆●



Silver Haze (Tile)



Iron Age Gloss

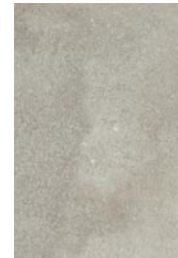

Pumice Matt



Concrete Matt



Slate Matt

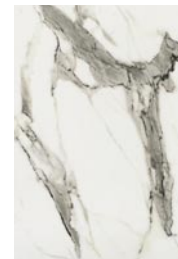

White Marble Gloss

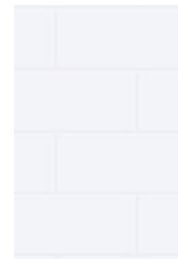

New York White (Tile)

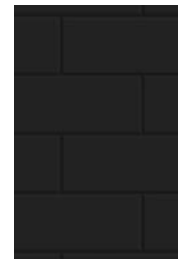

New York Black (Tile)

JOINER COLOURS

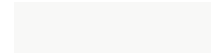

Snow White

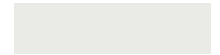

Carrara Ice



Dusk Grey



Midnight Marble



Brushed Aluminium (PVC)



Black

TECHNICAL DETAILS

Sheet Sizes:
All colours available in;
2400 mm x 1200 mm

Other sizes for selected colours only

- ▲ 2400 mm x 900 mm
- ◆ 2100 mm x 900 mm
- 1800 mm x 900 mm

JOINERS

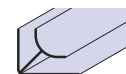

Internal Corner

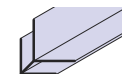

External Corner

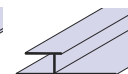

Sheet Joiner

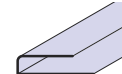

Top/End Cap

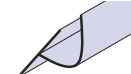

Bath Mould

Safety First

When working in areas that generate dust it is advisable that you wear protective goggles, a dust mask and work gloves. Storage and work areas should be well ventilated.

Conditioning

It is important that you condition your panels by placing them in the room where they will be installed. Leave a space between sheets to allow for air circulation. For rooms above ground level, allow panels to condition for 24 hours. For rooms below ground level, allow for 48 hours.

Handling

To avoid scratching the surface of your panels, ensure that the work area remains clean, avoid contact between the panel and abrasive surfaces and take care when moving the panel to avoid chipping any edges.

Planning and Preparation

Calculate the number of panels required to complete your project and gather the necessary tools and materials from the following list:

- Tape measure
- Spirit level
- Pencil
- Carpenter's square
- Fine tooth handsaw or fine tipped tungsten machine saw
- Fine tooth hacksaw
- Hand plane
- Sandpaper
- Timber battens
- Electric drill & hole cutting bit
- Nails
- Hammer
- Staple gun
- Caulking gun
- Adhesive (we recommend a synthetic rubber based adhesive like Selley's Liquid Nails High Strength or Sikaflex 11FC. Rigid or semi-rigid adhesive is not recommended.)
- Sealant (we recommend Selley's All Clear or Selley's Bathroom & Kitchen Sealant)
- Caulking compound (we recommend Selley's Bathroom & Kitchen Silicone)
- Wood block / cloth
- Mineral spirits
- Colour-matched joiners to join panels and finish off installation

Silicone Joints

WallART Linear can be installed using a butt joint system rather than the matching joining strips. If you choose to do this, apply bond breaker tape to the timber frame at the centre of the joint before fixing the sheet to the wall. Leave a 3mm gap between the sheets using an off cut as a spacer.

Run masking tape down the sides of each joint and fill with a matching bathroom silicone.

Trowel off any surplus and remove masking tape. Wipe off any excess silicone on the surfaces using a damp cloth or mineral turpentine.

Installation on Plasterboard and Cement Sheets

WallART Linear can be fitted to walls that are already lined with a flat sheet, such as plasterboard and cement sheeting. Plasterboard sheeting can only be used in low humidity applications.

In wet areas, cement sheeting such as Hardie's Villaboard is required. Walls subject to possible dampness or high moisture pick-up should not have WallART Linear fixed direct, but installed to dressed timber frame, or the wall surface must be waterproofed with an impermeable coating.

Installation requires the following:

- All surfaces must be clean and free of grease, oil, dust and paint.
- Walls must be completely dry.
- Walls must be flat and square.
- Use profiles in these applications.
- Use a 5mm bead of adhesive around the edge of the sheet.
- Use a zig zag pattern of 5mm bead of adhesive making sure that the bead is within 15 - 20mm of the sheet edge.
- Press the sheet against the wall to transfer the adhesive to the wall. Remove the sheet and hold away from the wall to allow adhesive to become tacky. This will take approximately 5 - 15 minutes depending on climatic conditions.
- Once tacky, press the sheet back against the wall and continue as before.

Care and Maintenance

To maintain its original luster, your panels should be cleaned with a mild liquid non-abrasive cleanser. Avoid using abrasive powder cleansers.

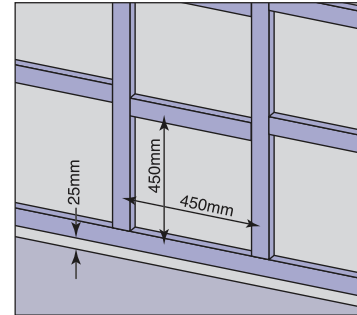

1 We recommend that panels be fixed to a framework of timber battens 50mm x 25mm in size with a maximum spacing of 450mm between the vertical and horizontal battens. Ensure the lowest point of the frame is at least 25mm above the floor or shower base. Where two panels are joined together, place a timber batten behind the join and ensure the timber framework provides a flat surface.

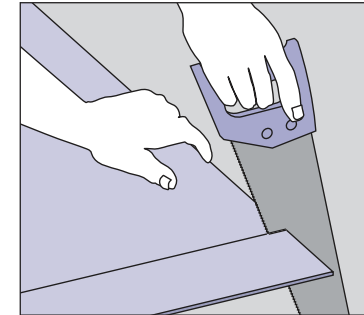

2 When cutting straight lines use a fine tooth handsaw and always cut with the panel face up. If using a fine tipped tungsten machine saw ensure the panel is face down. Sand or hand plane cut edges to achieve a smooth finish. Use a fine toothed hacksaw to cut your colour-matched joiners to size.

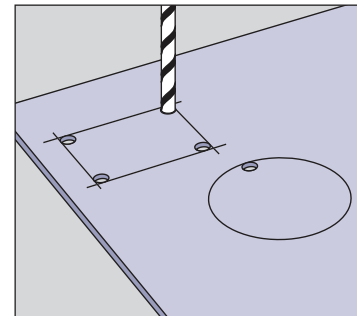

3 When cutting holes for taps, shower fitting and pipes measure and mark the outline of the area on the face of the panel, then drill and cut with the face up. For holes 20mm or larger in diameter, a 2mm allowance for expansion should be made. These expansion gaps should later be sealed with silicone. Do not cut square corners in your panel. Drill holes on the inside of each corner you have marked and cut along your outlined area up to each drill hole. Lightly sand the inside edges of your cutout area to remove any burrs.

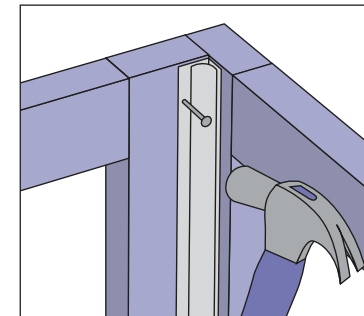

4 Begin in one corner by nailing or stapling an internal corner joiner to the timber frame.

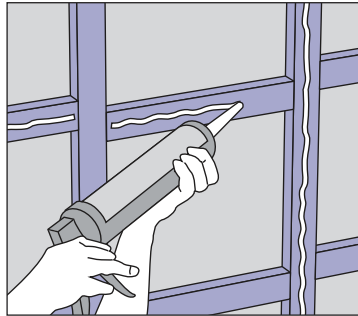

5 Apply a 5mm bead of adhesive to the face of each timber batten that the first panel will be applied to.

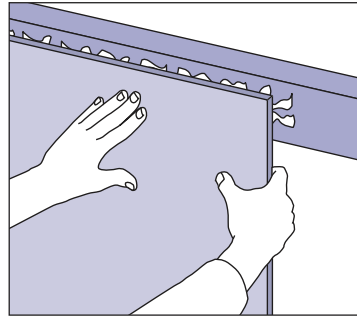

6 Rub the back of each panel with coarse sandpaper in the areas that will make contact with the adhesive. Work with one sheet at a time, applying adhesive and installing. Position the panel carefully and press firmly to make contact with adhesive. Remove the panel until the adhesive becomes touch dry (approximately 5 to 10 minutes) and follow the adhesive manufacturer's instructions.

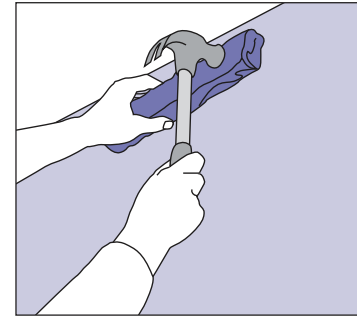

9 Use a wood block wrapped in a soft cloth to work across the surface of each panel, tapping the block gently with a hammer to ensure the adhesive on all battens makes contact with the panel, particularly around the edges.

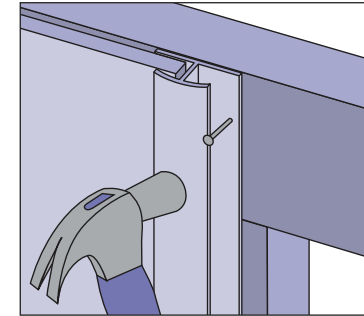

10 Allow for a 3mm expansion gap on each side of the next joiner and nail or staple the joiner to the frame.

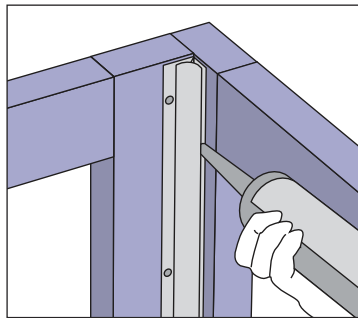

7 Place a bead of silicone sealant along the inside of each joiner (internal corner, sheet joiner, etc.) to create a 3mm expansion gap.

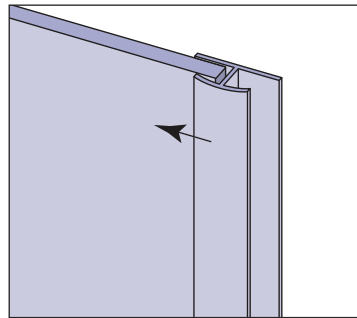

8 Slide the panel into the joiner and position the panel carefully. Fix the next joiner to the free edge of the panel and press the sheet into its final position.

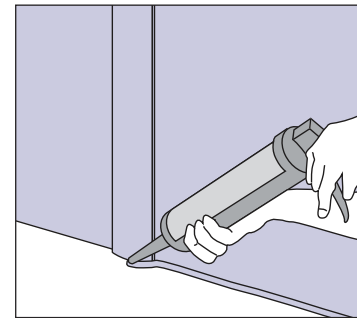

11 Continue this process to fix panels around each wall and seal gaps at the base of each panel using silicone sealant.

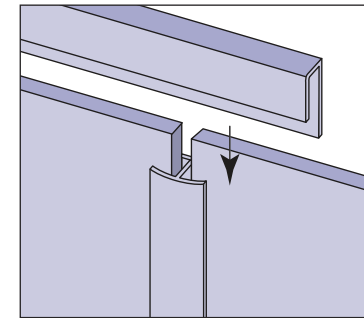

12 Upper and lower edges may also be finished using end caps. Should this joiner be used, ensure all lengths of vertical sheet joiner finish 11mm short of edges. A bath mould is recommended for the lower edge of panels butting against a bath rim.

***Important:** Some sheets have a protective film on both sides. This must be removed before installation